

VALVOLA BILANCIAMENTO, BLOCCO E CONTROLLO MOVIMENTO A SEMPLICE EFFETTO CON COLLETTORE IN LINEA
SINGLE COUNTERBALANCE VALVE WITH IN LINE BODY

REGOLAZIONE
ADJUSTMENT →

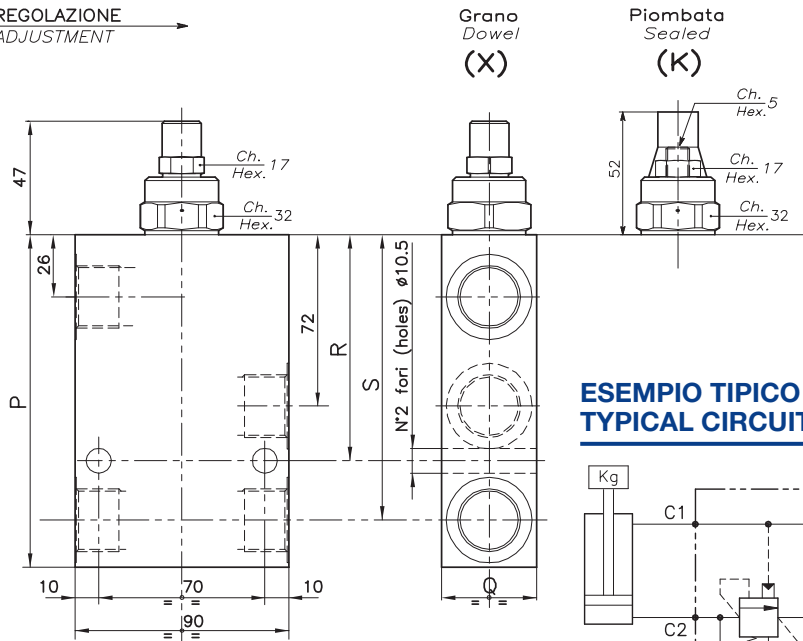

ESEMPIO TIPICO DI CIRCUITO
TYPICAL CIRCUIT EXAMPLE

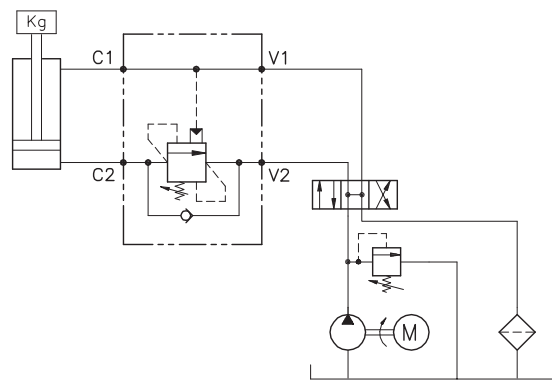

DIMENSIONI
DIMENSIONS

Campo taratura Setting range	P	Q	R	S	Attacchi Port size V2-C2 V1-C1 GAS (BSPP)	Luce nominale Rated size DN	Portata max Max flow-rate l/min - GPM	Corpo Body
265	140	40	95	120	3/4"	12	120-31	Acciaio Steel
266	165	50	107	142	1"	14	160-42	Acciaio Steel

CODICE DI ORDINAZIONE
HOW TO ORDER

001 . 265 . 0 X 0 . A

Campo taratura / Setting range
265
266

Campo taratura 60÷350 bar (molla colore giallo)
Setting range 60÷350 bar (yellow spring)

Taratura standard (Q=5 l/1')
Std. bar setting Q=5 l/1')
250 bar

Incr. press. - bar giro/vite
Pressure rise - turn of screw
(125)

Rapporto
di pilotaggio
Pilot ratios

O 6.2: 1
G 4.1: 1

Regolazione
Adjustment

X Grano - Dowel
K Piombata - Sealed

Collettore
Body

A Acciaio
zincato
Zinc plated
steel